

PARTS DRAWING / SCHEMA DES PIÈCES / DIAGRAMA DE PIEZAS

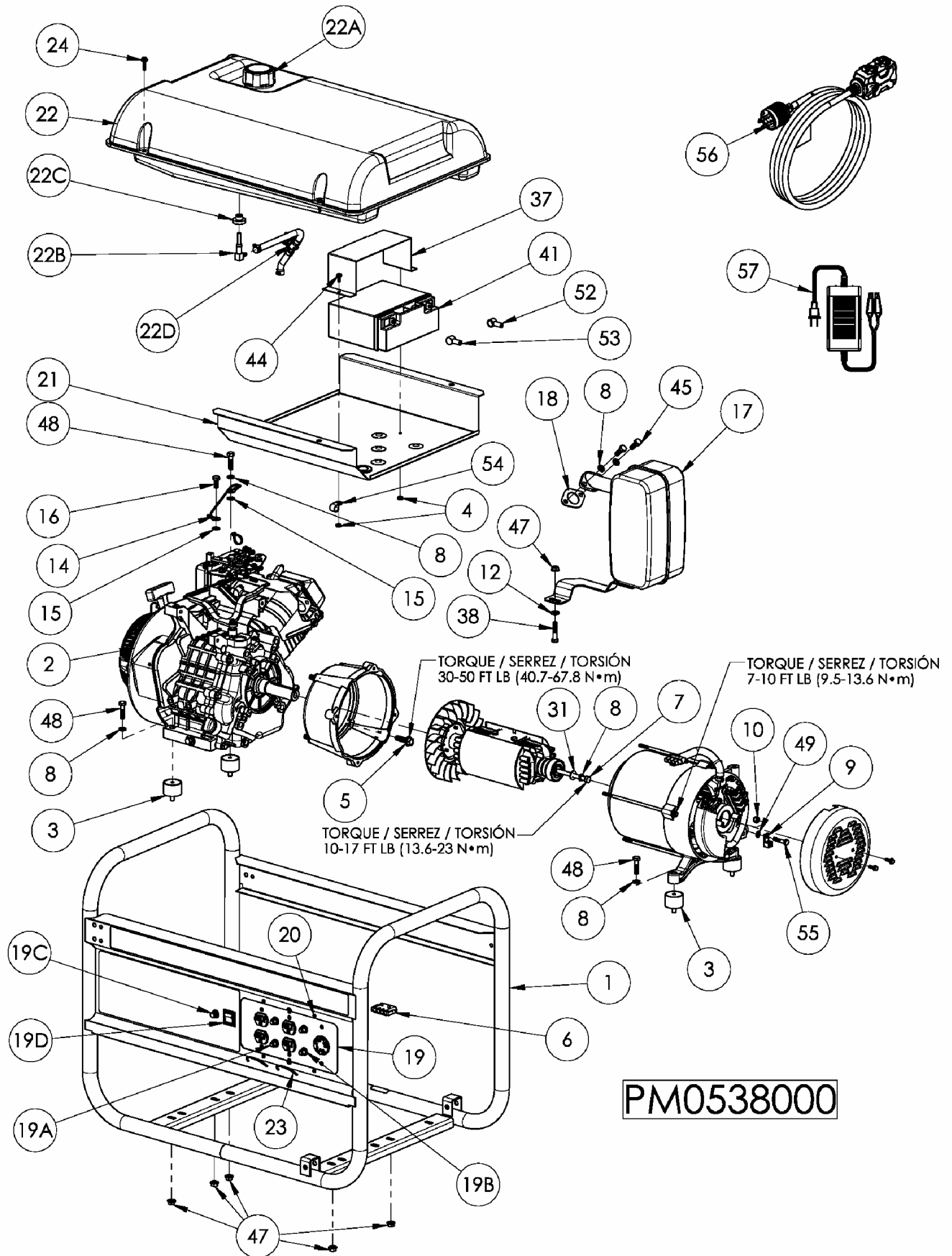

PM0538000

PARTS LIST / LISTE DES PIÈCES / LISTA DE PIEZAS

REF. NO.	PART NO.	DESCRIPTION	DESCRIPTION	DESCRIPCIÓN	QTY
1	0064205	Carrier, assembly	Ensemble transport	Transportador, conjunto	1
2	Note A	Engine 15 hp B&S OHV	Moteur	Motor	1
3	0051094	Isolator	Sectionneur	Aislador	4
4	0051930	Nut hex #10-32 Keps	Écrous #10-32	Tuerca #10-32	2
5	0057512	Bolt whz 3/8-16 x 1 1/4	Boulon	Perno	4
6	0062797	Connector, panel	Connecteur, tableau	Conector, panel	1
7	0063935	Bolt, hex 5/16-24 x 9.50	Boulon	Perno	1
8	Note B	Washer, lock 5/16	Contre-écrou 5/16	Arandela, de cierre 5/16	7
9	0008854	Lug, ground	Oeillet de mise à la terre	Terminal, tierra	1
10	0040832	Nut, nyloc 1/4-20	Écrous nyloc 1/4-20	Tuerca, nyloc 1/4-20	3
11	Note B	Bolt, 1/4-20 x 1 1/2	Boulon	Perno	2
12	Note B	Washer, flat 5/16	Rondelle plates 5/16	Arandela, plana 5/16	5
13	0048736	Nut, nyloc 5/16-18	Écrous nyloc 5/16-18	Tuerca, nyloc 5/16-18	4
14	0049224	Assembly, ground wire	Ensemble fil de masse tressé a tierra	Conjunto, cable trenzado	1
15	Note B	Washer, star external 5/16	Rondelle à dents externa 5/16	Arandela, estrella	2
16	Note B	Bolt, hex 5/16-18 x 3/4	Boulon, tête hex 5/16-18 x 3/4	Perno	1
17	0064209	Muffler	Silencieux	Silenciador	1
18	0061129	Gasket	Joint	Empaquetadura	1
19	0064210	Panel, wired	Tableau complet câblé	Panel, cabeado completo	1
19A	0049071	Circuit Breaker 20 amp	Disjoncteurs 20 amp	Cortacircuitos 20 amp	2
19B	0048337	Circuit Breaker 35 amp	Disjoncteurs 35 amp	Cortacircuitos 35 amp	2
19C	0063672	Start button	Bouton de début	Botón de comienzo	1
19D	0063673	Switch, Rocker	Interrupteur	Interruptor	1
20	0062462	Screw #6-20 x .38 Type B	Vis	Tornillo	4
21	0064212	Shield, heat	Écran de chaleur	Pantalla para el calor	1
22	Note C	Fuel tank assembly	Ensemble complet du réservoir	Conjunto tanque	1
22A	0056231	Fuel Cap	Capuchon	Tapa de combustible	1
22B	0050766	Fuel elbow 90° with filter	Coude de carburant avec le filtre	Codo combustible con filtro	1
22C	0062673	Fuel Bushing	Bague d'essence	Buje de combustible	1
22D	0049920	Fuel shut-off	Alimenter d'arrêt	Abastecza de combustible válvula	1
23	0055982.01	Cord Keeper™	Cord Keeper™	Cord Keeper™	2
24	0058618	Screw #10 x 1	Vis	Tornillo	4
25	0064308	Handle	Poignée	Manija	2
26	Note B	Bolt, 5/16-18 x 2 1/4	Boulon	Perno	2
27	Note B	Washer, flat 3/8	Rondelle plates 3/8	Arandela, plana 3/8	6
28	0063771	Wheel	Roue	Rueda	2
29	0055894	Rubber Foot	Pied	Pie	2
30	0062174	Lanyard	Lanyard	Acollador	2
31	0058933	Washer, flat 1/4 W	Rondelle plates 1/4 large	Arandela, plana 1/4 lejos	1
32	Note B	Bolt, 3/8-16 x 4.25	Boulon	Perno	2
33	0057578	Nut, nyloc 3/8-16	Écrous nyloc 3/8-16	Tuerca, nyloc 3/8-16	6
34	0062502	Pin, release	Épingle de relâchement	Alfileres de la liberación	2
35	0058955	Cap, plastic	Capuchon	Tapa	2
36	Note B	Washer, flat 1/4	Rondelle plates 1/4	Arandela, plana 1/4	2
37	0064222	Bracket, battery hold-down	Support, Botte	Soporte, batería	1
38	Note B	Bolt, 5/16-18 x 1 1/2	Boulon	Perno	1
39	0062433	Wheel spacer	Bague d'espacement	Espaciador de la rueda	2
40	0062495	Grip, handle	Poignée	Empuñadura	2
41	0063574	Battery 12V 18AH	Batterie	Batería	1
42	Note B	Bolt, 5/16-18 x 1	Boulon	Perno	2
43	0063546	Bracket, foot	Support de pied	Soporte del pie	1
44	0047864	Screw #10-32 x .50	Vis	Tornillo	2
45	Note B	Bolt, M8 x 22mm	Boulon	Perno	2
46	0063164	Spacer, handle bracket	Entretoise	Espaciador	2
47	0057254	Nut, hex flg 5/16-18	Écrous 5/16-18	Tuerca 5/16-18	6
48	Note B	Bolt, 5/16-18 x 1 1/4	Boulon	Perno	4
49	Note B	Washer, star external 1/4	Rondelle à dents externa 1/4	Arandela, estrella	1
50	0049352	Washer, flat 5/16 W	Rondelle plates 5/16 large	Arandela, plana 5/16 lejos	4
52	0064221	Boot, black	Botte, noir	Bota, negro	1
53	0064220	Boot, red	Botte, rouge	Bota, rojo	1
54	0047706	Clamp, nylon 1/2	Collier	Abrazadera	1
55	Note B	Bolt, 1/4-20 x 1 1/4	Boulon	Perno	1
56	0063876	Cordset, 25 foot 30 amp	Ensemble de cordons, 25 pieds 30A	Juego de cordón, 25 pies 30 amperios	1
57	0064217	Charger 12V	Chargeur 12V	Cargador 12V	1

PARTS LIST / LISTE DES PIÈCES / LISTA DE PIEZAS

Ref No.	Part No.	Description	Description	Descripción	Qty
51	0063821	Generator head, Sumec	Tête de la génératrice, Sumec	Cabezal del generador, Sumec	1
51A	0063300	Adapter, engine	Adaptateur pour moteur	Adaptor, motor	1
51B	0063940	Rotor	Rotor	Rotor	1
51C	0063941	Stator	Stator	Estator	1
51D	0063942	Band, stator cover	Bande	Banda	1
51E	0063943	Bolt, M6 x 195	Boulon	Perno	4
51F	0063229	Support, bearing	Support, roulement	Soporte, Cojinete	1
51G	0063230	Brush module	Brosser le module	Cepille módulo	1
51H	0063231	Screw flg M5 x 16mm	Vis	Tornillo	8
51I	0063948	AVR module	La tension automatique régulatrice	El regulador automático del voltaje	1
51J	0063944	Bolt, M5 x 230	Boulon	Perno	2
51K	0063235	Nut, nyloc M5	Écrous nyloc	Tuerca nyloc	2
51L	0063236	Terminal block	Bloc délimitant	Bloque terminal	1
51M	0063237	Washer M5	Rondelle	Arandela	8
51N	0063238	Washer, lock M5	Contre-écrou	Arandela, de cierre	10
51O	0063239	Nut M5	Écrous	Tuerca	8
51P	0063240	Cover, end	Couvercle	Tapa	1
51Q	0063241	Screw flg M5 x 8mm	Vis	Tornillo	2
51R	0063225	Fan	Ventilateur	Ventilador	1
51S	0063364	Screw M5 x 20mm	Vis	Tornillo	4
51T	0063365	Bearing	Roulement	Cojinete	1
51U	0063932	Stator harness	Harnais de stator	Arreos de estator	1

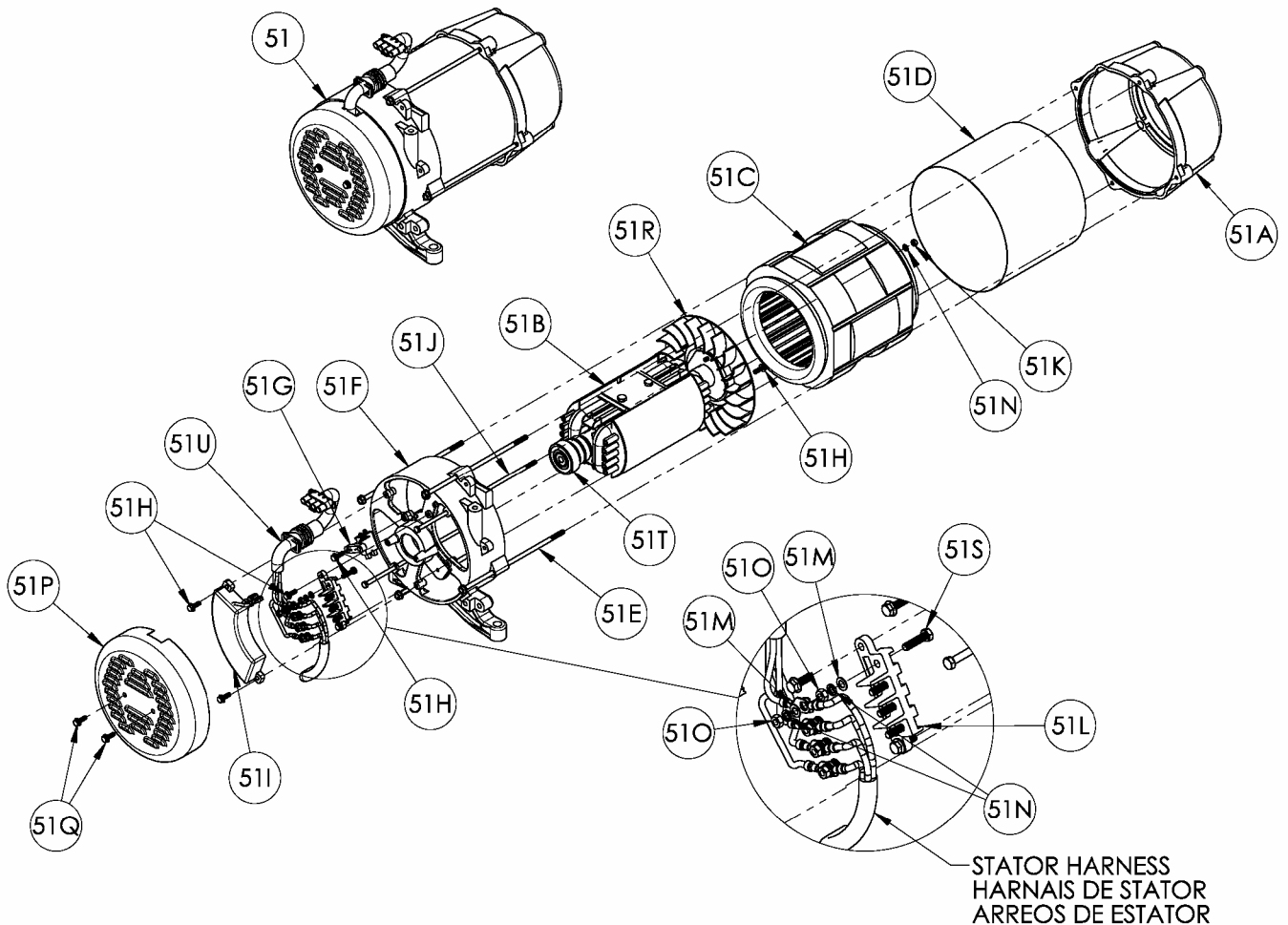

This insert replaces the generator head parts list in your manual insert serial number ending in B1.
 Cette insertion remplace les liste des pièces de tête de génératrice dans votre insertion manuel
 par celles-ci.

Esta adición reemplaza las lista de piezas de cabezal del generador en su adición manual.

PARTS LIST / LISTE DES PIÈCES / LISTA DE PIEZAS

Ref No.	Part No.	Description	Description	Descripción	Qty
60	0064546	Generator head, Sumec	Tête de la génératrice, Sumec	Cabezal del generador, Sumec	1
60A	0063300	Adapter, engine	Adaptateur pour moteur	Adaptor, motor	1
60B	0064834	Rotor	Rotor	Rotor	1
60C	0064835	Stator	Stator	Estator	1
60D	0064836	Band, stator cover	Bande	Banda	1
60E	0064837	Bolt, M6 x 200	Boulon	Perno	4
60F	0063229	Support, bearing	Support, roulement	Soporte, Cojinete	1
60G	0063230	Brush module	Brosser le module	Cepille módulo	1
60H	0063231	Screw flg M5 x 16mm	Vis	Tornillo	8
60I	0063948	AVR module	La tension automatique régulatrice	El regulador automático del voltaje	1
60J	0064838	Bolt, M5 x 235	Boulon	Perno	2
60K	0063235	Nut, nyloc M5	Écrous nyloc	Tuerca nyloc	2
60L	0063236	Terminal block	Bloc délimitant	Bloque terminal	1
60M	0063237	Washer M5	Rondelle	Arandela	8
60N	0063238	Washer, lock M5	Contre-écrou	Arandela, de cierre	10
60O	0063239	Nut M5	Écrous	Tuerca	8
60P	0063240	Cover, end	Couvercle	Tapa	1
60Q	0063241	Screw flg M5 x 8mm	Vis	Tornillo	2
60R	0063225	Fan	Ventilateur	Ventilador	1
60S	0063364	Screw M5 x 20mm	Vis	Tornillo	4
60T	0063365	Bearing	Roulement	Cojinete	1
60U	0063932	Stator harness	Harnais de stator	Arreos de estator	1

