

 **English** **10 HP Electric Two–Stage, Cast Iron Pump, Air Compressor with SC-46 pumps**

 **French** **Compresseur d’air électrique biétagé de 10 CV et munis de pompe SC-46**

 **Spanish** **Compresor de aire con bomba de hierro colado y motor eléctricos de dos etapas de 10 HP, con bomba SC-46**

*NOTE: These units require a magnetic starter.

*REMARQUE: Ces compresseurs nécessitent l’installation d’un démarreur magnétique.

*NOTA: Estas unidades requieren la instalación de un arrancador magnético.

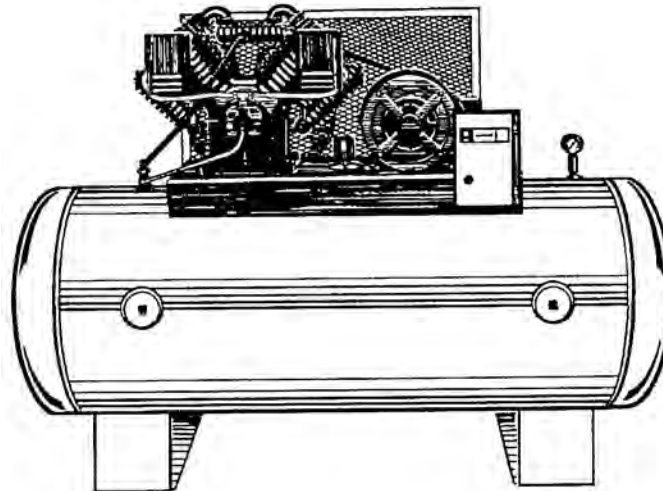

Specification Chart _____ **Tableau des spécifications** _____ **Cuadro de especificaciones**

MODEL NO. (MODÈLE) (MODELO)	H.P. (CV)	TANK CAPACITY GALLONS (CAPACITÉ DU RÉSERVOIR - LITRES) (CAPACIDAD DEL TANQUE - LITROS)	VOLTAGE/ AMPS/PHASE (TENSION/ AMPS/PHASE) (VOLTAJE/ AMP/FASE)	CFM (l/min) @ 100 PSI (7 bar)	CFM (l/min) @ 175 PSI (12 bar)	KICK-IN PRESSURE (PRESSION D’OUVERTURE) (PRESION DE CONEXION)	KICK-OUT PRESSURE (PRESSION DE FERM.) (PRESION DE DESCONEXION)
H9919946	10	Horiz 120 (454)	460/12.5/3	36 (1020)	34 (960)	145 (10 bar)	175 (12 bar)



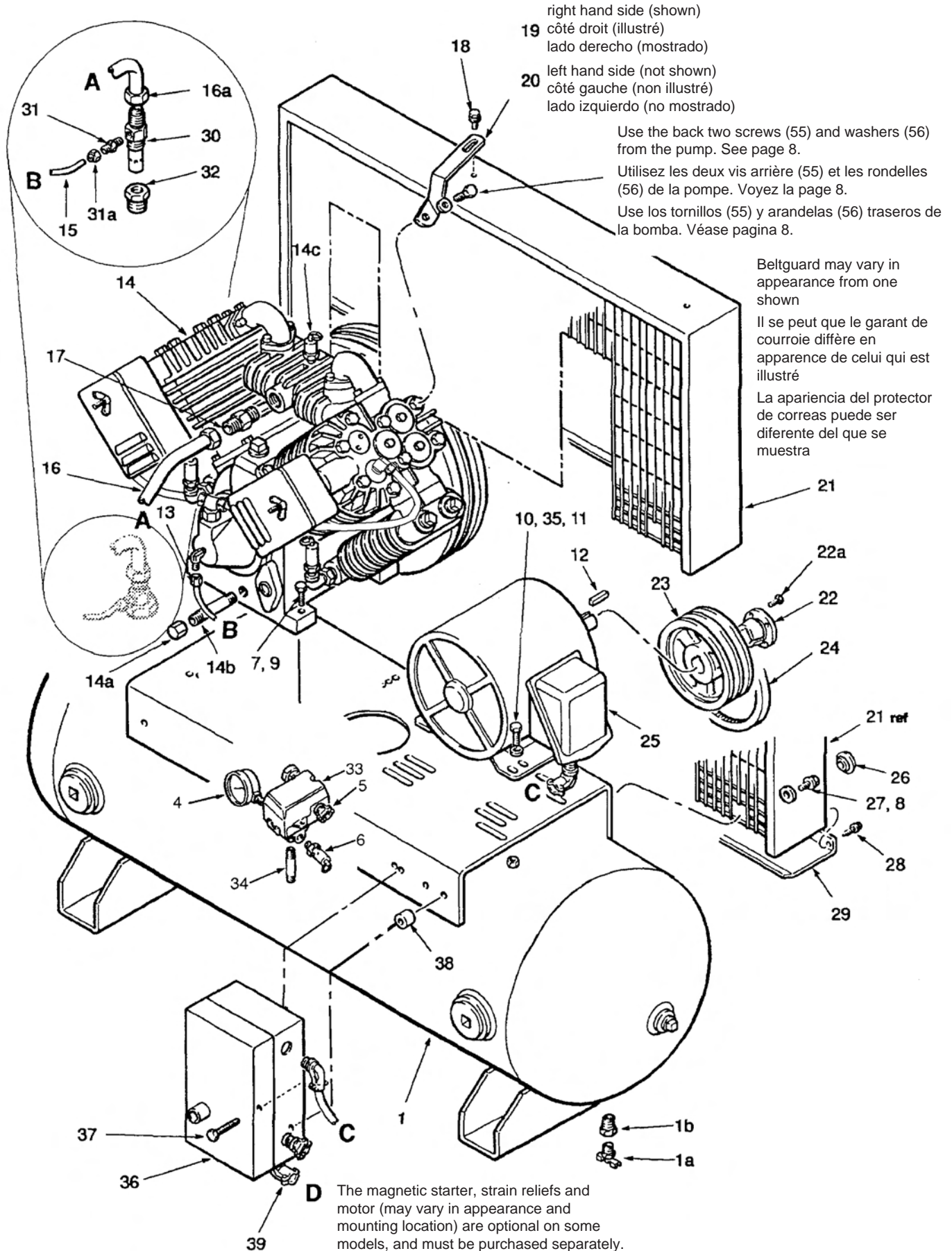

Questions? See back page. _____ Questions ? Consultez la page final. _____ ¿Preguntas? Vea la página final.



PARTS LIST

LISTE DES PIÈCES

LISTA DE LAS PIEZAS

Item Art	Part No N° / P	Qty Qté	 English	 French	 Spanish
Art	Núm / P	Cant	Description	Description	Descripción
1	515-0353	1	Tank assy	Ensemble du réservoir	Conjunto de tanque
1a	072-0001	1	Petcock, 1/4" NPT.....	Robinet de décompression	Llave de desagüe
1b	N/A	1	Bushing, 1/2" NPT x 1/4" NPT	Bague.....	Buje
2	N/A	1	Bushing, 1" NPT x 1/4" NPT	Bague.....	Buje
4	032-0025	1	Gauge, 300 PSI	Jauge	Manómetro
5	071-0002	1	Strain relief connector.....	Soulagement de traction	Aliviador de esfuerzo
6	136-0007	1	Valve, relief, 200 PSI.....	Soupape.....	Válvula
7	N/A	4	Screw, 7/16" - 14 x 2" lg.....	Vis	Tornillo
8	N/A	4	Washer, 3/8"	Rondelle.....	Arandela
9	N/A	4	Nut, 7/16" - 14.....	Écrou.....	Tuerca
10	N/A	4	Screw, 3/8" - 16 x 1" lg.....	Vis	Tornillo
11	N/A	4	Nut, 3/8" - 16, heavy	Écrou.....	Tuerca
12	146-0007	1	Key 5/16" x 3/16" x 1 1/4" lg.....	Clé.....	Chaveta
13	058-0017	1	Compression nut & sleeve.....	Écrou de compression	Tuerca de compresión
14	040-0212	1	Pump assy.....	Pompe.....	Bomba
14a	062-0101	1	Cap, pipe, 3/8" NPT.....	Capuchon.....	Tapa
14b	065-0040	1	Nipple, 3/8" NPT x 4" lg	Manchon fileté.....	Niple
14c	136-0047	1	Valve, relief, 225 PSI.....	Soupape.....	Válvula
14d	136-0046	2	Valve, relief, 75 PSI.....	Soupape.....	Válvula
15	145-0212	1	Tube, bleeder, B to B (copper)	Tube	Tubo
			also order 058-0017, qty 2		
16	145-0239	1	Tube, transfer, A to A (copper).....	Tube	Tubo
			includes (2) item 16a		
16a	N/A	2	Nut, flared	Écrou.....	Tuerca
17	068-0504	1	Connector	Connecteur.....	Conector
18	059-0012	2	Bolt, lock 5/16" - 18 x 1/2" lg.....	Boulon	Perno
19	114-0188	1	Bracket, belt guard, 45° bend	Support.....	Soporte
			right hand (shown)		
20	114-0189	1	Bracket, belt guard, 45° bend	Support.....	Soporte
			left hand (not shown)		
21	142-0085	1	Beltguard	Garant de courroie	Protección de correa
22	004-0002	1	Hub	Moyeu	Cubo
22a	NA	2	Screw, 1/4" x 3/4" lg.....	Vis	Tornillo
23	006-0031	1	Pulley.....	Poulie	Polea
24	008-0059	2	V-belt, B80	Courroie	Correa
25	160-0026	1	Motor, 10 HP 3 PH.....	Moteur	Motor
26	093-0005	5	Plug, button.....	Bouchon	Tapón
27	N/A	4	Screw, 3/8" - 16 x 3/4" lg.....	Vis	Tornillo
28	N/A	4	Screw, #10 x 3/4" lg.....	Vis	Tornillo
29	125-0120	1	Underpan	Tôle inférieure	Bandeja inferior
30	031-0059	1	Check valve, flared	Clapet de retenue.....	Válvula de contraflujo
31	068-0002	1	Connector	Connecteur.....	Conector
31a	058-0017	1	Compression nut & sleeve.....	Écrou de compression	Tuerca de compresión
32	N/A	1	Bushing.....	Bague.....	Buje
33	034-0120	1	Switch, pressure	Interrupteur.....	Interruptor
34	N/A	2	Nipple, 1/4" NPT x 2 1/2" lg	Manchon fileté.....	Niple
35	N/A	4	Washer	Rondelle.....	Arandela

must be purchased separately			doit être acheté séparément			se debe comprar por separado		
36	001-0156	or	Magnetic starter, 10 HP, 3 PH	Démarrateur magnétique	Arrancador magnético			
37	059-0245	2	Screw.....	Vis	Tornillo			
38	114-0220	2	Spacer	Entretoise	Espaciador			
39	NA	1	Strain relief, 3/8" straight.....	Soulagement de traction	Aliviador de esfuerzo			
	NA	1	Strain relief, 3/8" 90°					
	NA	2	Strain relief, 1/2" 90°					

*N/A - These are standard parts available at your local hardware store.

*N/A - Ces pièces sont des pièces standard disponibles en quincaillerie.

*N/A - Estas son piezas estándares disponibles en su ferretería local.

SC46 PUMP 040-0212

PUMP SPECIFICATIONS

WEIGHT - 312 LBS
 CAPACITY - 65 OZ.
 MAX RPM - 800
 OIL GRADE - Low carbon compressor oil
 PGS III (018-0053SP) or SLC 1
 (018-0015SP)

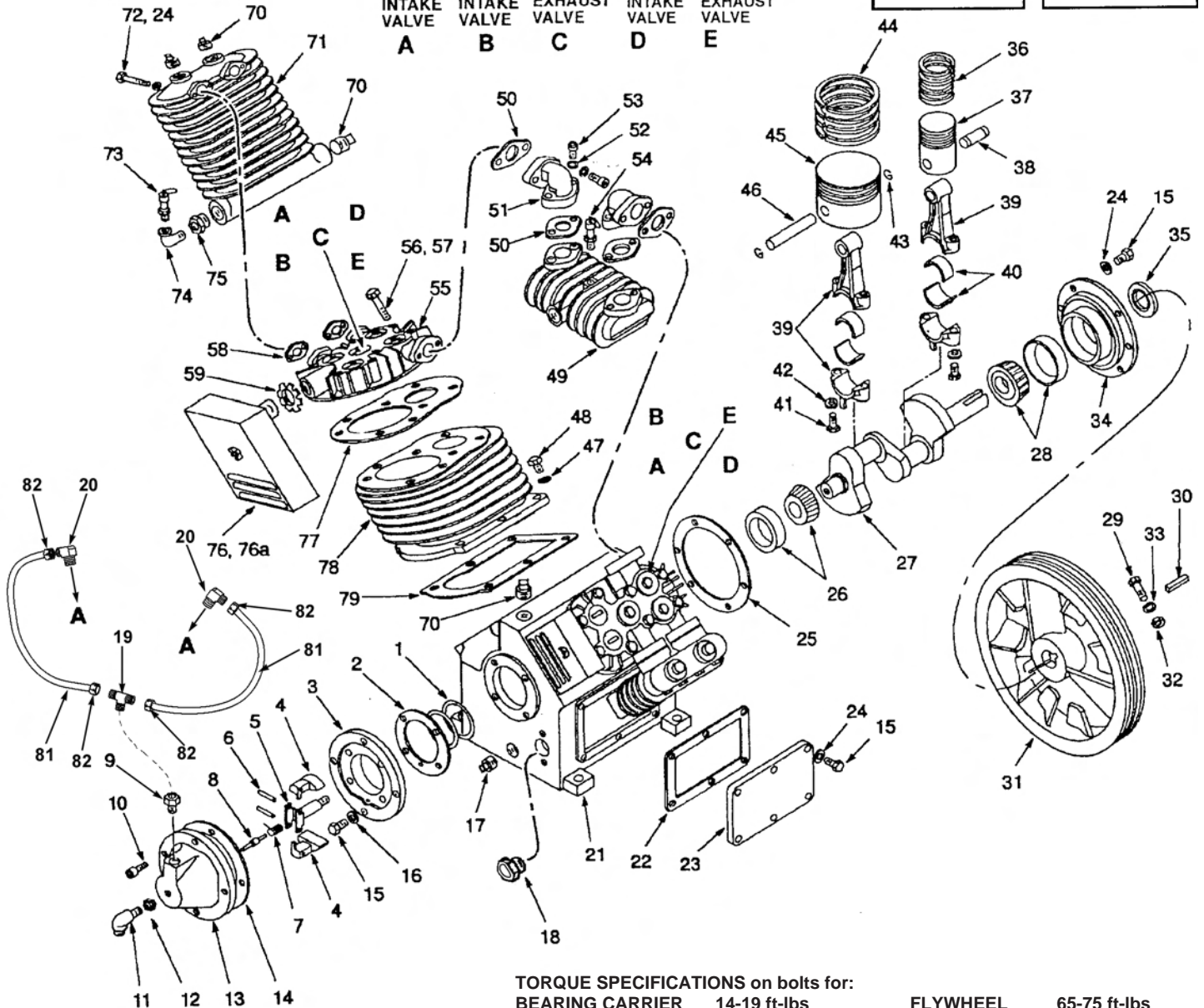
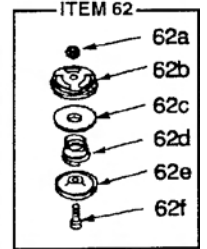
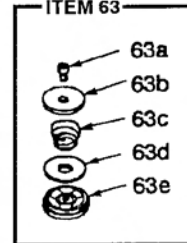
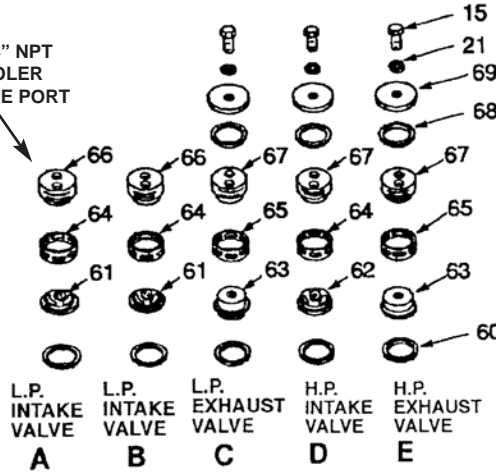
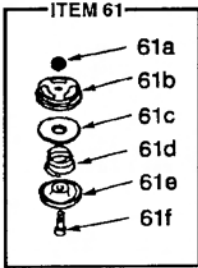

NOTE: 3/4" NPT
 AFTERCOOLER
 DISCHARGE PORT





TORQUE SPECIFICATIONS on bolts for:

BEARING CARRIER	14-19 ft-lbs	FLYWHEEL	65-75 ft-lbs
UNLOADER COVER	9-12 ft-lbs	SIGHT GLASS	14-19 ft-lbs
AFTERCOOLER	14-19 ft-lbs	CYLINDER	19-27 ft-lbs
INTERCOOLER	14-19 ft-lbs	ROD	34-37 ft-lbs
VALVE RETAINERS	90-100 ft-lbs	HEAD	32-37 ft-lbs
VALVE COVER	14-19 ft-lbs	VALVE	5-12 ft-lbs
SIDE COVER	14-19 ft-lbs		

Pump assy 040-0212 - Ensemble du pompe - Conjunto de bomba



Item Art	Part No N° / P Núm / P	Qty Qté Cant	 English Description	 French Description	 Spanish Descripción			
1	046-0175 046-0176 046-0177	AR	Shim, bearing adj., .005 thick Shim, bearing adj., .010 thick Shim, bearing adj., .020 thick	Cale	Calzo			
2	046-0227	1	Gasket, adapter plate	Joint	Empaquetadura			
3	077-0070	1	Plate, adapter, centrif. unloader	Plaque	Placa			
4	096-0009	2	Weight	Poids	Peso			
5	114-0112	1	Holder, weight	Manche	Soporte			
6	107-0015	2	Pin	Goupille	Pasador			
7	055-0051	1	Spring	Ressort	Resorte			
8	078-0011	1	Plunger	Piston	Embolo			
9	056-0056	1	Breather, crankcase	Reniflard	Respiradero			
10	059-0156	4	Screw, M6 x 20 mm lg	Vis	Tornillo			
11	031-0057	1	Valve, air, w/ valve core	Soupape	Válvula			
12	058-0084	1	Nut, brass, M10	Écrou	Tuerca			
13	077-0071	1	Housing, centrifugal unloader	Corps	Compartimiento			
14	046-0171	1	Gasket	Joint	Empaquetadura			
15	059-0166	21	Screw, M8 x 20 mm lg	Vis	Tornillo			
16	060-0070	4	Washer, lock, 8 mm	Rondelle	Arandela			
17	062-0004	1	Plug, oil drain	Bouchon	Tapón			
18	032-0071	1	Oil level sight glass	Verre de vue de niveau d'huile	Cristal de la vista del nivel de aceite			
19	069-0021	1	Tee, breather	Pièce en t, Reniflard	Te, Respiradero			
20	064-0066	2	Breather elbow	Coude de reniflard	Codo del respiradero			
21	049-0028	1	Crankcase	Carter	Cárter			
22	046-0170	1	Gasket, side cover	Joint	Empaquetadura			
23	077-0072	1	Cover, side	Couvercle	Tapa			
24	060-0061	26	Washer, copper .52" O.D. x .32" I.D.	Rondelle	Arandela			
25	046-0168	1	Gasket, front cover	Joint	Empaquetadura			
26	051-0054	1	Bearing set, rear	Jeu de roulements	Conjunto de cojinete			
27	053-0052	1	Crankshaft	Vilebrequin	Cigüeñal			
28	051-0053	1	Bearing set, front	Jeu de roulements	Conjunto de cojinete			
must be purchased separately			doit être acheté séparément			se debe comprar por separado		
29	059-0163	1	Bolt, M16 x 80 mm lg	Boulon	Perno			
30	146-0015	1	Key, flywheel	Clé	Chaveta			
31	044-0051	1	Flywheel, 19" O.D.	Volant-moteur	Volante			
must be purchased separately			doit être acheté séparément			se debe comprar por separado		
32	058-0086	1	Nut, M16	Écrou	Tuerca			
33	060-0069	1	Washer, lock, 16 mm	Rondelle	Arandela			
34	045-0044	1	Bearing carrier, front	Support, roulement	Portador, cojinete			
35	046-0179	1	Seal, shaft	Joint	Sello			
36	054-0178	1	Ring set, high pressure	Jeu de segment	Juego de anillos			
37	048-0081	2	Piston, high pressure	Piston	Pistón			
38	052-0028	2	Pin, wrist, high pressure	Goupille	Pasador			
39	047-0084	4	Rod, connecting (cast iron)	Tige	Varilla			
40	051-0055	4 pair	Insert, bearing	Pièce rapportée	Inserto			
41	059-0154	8	Screw, rod, M10 x 45 mm lg	Vis	Tornillo			
42	060-0072	8	Washer, lock 10 mm	Rondelle	Arandela			
43	054-0119	4	Retaining ring	Anneau de retenue	Anillo retenedor			
44	054-0179	2	Ring set, low pressure	Jeu de segment	Juego de anillos			
45	048-0054	2	Piston, low pressure	Piston	Pistón			
46	052-0027	2	Pin, wrist, low pressure	Goupille	Pasador			
47	060-0063	12	Washer, copper .66 O.D. x .41 I.D.	Rondelle	Arandela			
48	059-0159	12	Screw, cylinder M10 x 30 mm lg	Vis	Tornillo			
49	082-0013	1	Aftercooler	Refroidisseur supplémentaire	Postrefrigerador			
50	046-0172	4	Gasket, manifold, aftercooler	Joint	Empaquetadura			
51	083-0008	2	Elbow, manifold, aftercooler	Coude	Codo			
52	060-0070	8	Washer, lock, 8 mm	Rondelle	Arandela			
53	059-0158	8	Bolt, manifold, M8 x 25 mm lg	Boulon	Perno			
54	136-0047	1	Valve, pressure relief, 225 PSI	Soupape	Válvula			
55	042-0055	1	Head, cylinder (side shown)	Tête	Cabeza			
	042-0056	1	Head, cylinder (other side)	Tête	Cabeza			

PARTS LIST / LISTE DE PIÈCES / LISTA DE LAS PIEZAS

Item Art	Part No N° / P	Qty Qté	 English	 French	 Spanish
<u>Art</u>	<u>Núm / P</u>	<u>Cant</u>	<u>Description</u>	<u>Description</u>	<u>Descripción</u>
56	059-0167	16	Bolt, head, M12 x 70 mm lg	Boulon	Perno
57	060-0105	16	Washer, M12	Rondelle	Arandela
58	046-0173	4	Gasket, intercooler.....	Joint.....	Empaquetadura
59	058-0087	2	Nut, conduit, 1"	Écrou.....	Tuerca
60	060-0062	10	Washer, copper	Rondelle	Arandela
61	043-0098	4	Intake valve assy, low pressure..... <i>includes items 61a-61f</i>	Ensemble de la soupape..... d'admission	Conjunto de válvula de admisión
61a	--	1	Nut, self-locking, hex jam.....	Écrou.....	Tuerca
61b	--	1	Seat, valve	Siège	Asiento
61c	--	1	Plate, valve	Plaque	Placa
61d	--	1	Spring, valve.....	Ressort.....	Resorte
61e	--	1	Guide, valve.....	Guide.....	Guía
61f	--	1	Bolt, M6 x 20 mm lg	Boulon	Perno
62	043-0099	2	Intake valve assy, high pressure	Ensemble de la soupape.....	Conjunto de válvula de admisión
62a	--	1	Nut, self-locking, hex jam.....	Écrou.....	Tuerca
62b	--	1	Seat, valve	Siège	Asiento
62c	--	1	Plate, valve	Plaque	Placa
62d	--	1	Spring, valve.....	Ressort.....	Resorte
62e	--	1	Guide, valve.....	Guide.....	Guía
62f	--	1	Bolt, M6 x 20 mm lg	Boulon	Perno
63	043-0100	4	Exhaust valve assy, high & low	Ensemble de soupape	Conjunto de válvula de escape
63a	--	1	Bolt, M6 x 12 mm lg.....	Boulon	Perno
63b	--	1	Guide, valve	Guide.....	Guía
63c	--	1	Spring, valve.....	Ressort.....	Resorte
63d	--	1	Plate, valve	Plaque	Placa
63e	--	1	Seat, valve	Siège	Asiento
64	043-0094	6	Spacer, intake valve	Entretoise	Espaciador
65	043-0095	4	Spacer, exhaust valve	Entretoise	Espaciador
66	058-0082	4	Retainer, valve, low pressure	Retenue.....	Retenedor
67	058-0083	6	Retainer, valve..... low pressure exhaust or high pressure intake and exhaust	Retenue.....	Retenedor
68	046-0174	6	Gasket, valve cover	Joint.....	Empaquetadura
69	077-0073	6	Cover, valve	Couvercle	Tapa
70	062-0006	7	Plug, pipe, 3/4" NPT		
71	082-0012	2	Intercooler.....	Refroidisseur intermédiaire	Enfriador intermedio
72	059-0157	8	Bolt, M8 x 90 mm lg.....	Boulon	Perno
73	136-0046	2	Valve, pressure relief, 75 PSI	Soupape.....	Válvula
74	064-0022	2	Elbow, 90° street, 1/4"		
75	063-0006	2	Bushing, reducer.....	Bague.....	Buje
76	019-0097	2	Filter, cannister assy..... <i>includes item 76a</i>	Filtre	Filtro
76a	019-0023	2	Element, filter replacement.....	Élément	Elemento
77	046-0166	2	Gasket, cylinder head	Joint.....	Empaquetadura
78	050-0030	2	Cylinder.....	Cylindre	Cilindro
79	046-0167	2	Gasket, cylinder/crankcase.....	Joint.....	Empaquetadura
80	056-0063	2	Oil dipper	Dipper d'huile	Cucharón del aceite
81	145-0402	2	Breather tube	Tube	Tubo
82	058-0017	4	Compression nut & sleeve.....	Écrou de compression	Tuerca de compresión

PARTS LIST / LISTE DE PIÈCES / LISTA DE LAS PIEZAS

AVAILABLE SERVICE KITS

Part No N° / P Núm / P	 <i>English</i>	 <i>French</i>	 <i>Spanish</i>
	Description	Description	Descripción
046-0185	Gaskets, complete set includes items 2, 14, 22, 25, 50, 55, 68, 79, washers 24, 47 and 60	Joints, jeu complet inclut les éléments 2, 14,22, 25, 50, 58, 68, 79, rondelles 24, 47 et 60	Juntas, conjunto completo incluye los artículos 2, 14, 22 25, 50, 58, 68, 79, arandelas 24, 47 y 60
046-0186	Gaskets, valve set includes items 68, 10 washers item 60 and six washers item 24	Joints, jeu de soupape inclut les éléments 68, 10 rondelles, les élément 60 et six rondelles, les élément 24	Juntas, conjunto des válvula incluye los artículos 68,10 arandelas, los artículo 60 y seis arandelas, los artículo 24
070-0020	Centrifugal unloader assy includes items 4–8	Ensemble de régulateur de pression centrifuge inclut les éléments 4 – 8	Conjunto de descargador centrifugo incluye los artículos 4 – 8
165-0065	Overhaul kit includes items 046-0185, 35, 36, 40, 44, 61, 62 and 63	Jeu de pièces de remise en état inclut les éléments 046-0185, 35, 36, 40, 44, 61, 62 et 63	Juego de reparación general incluye los artículos 046-0185, 35, 36, 40, 44, 61, 62 y 63



PARTS AND SERVICE

Replacement parts and service are available from your nearest authorized Service Center. If the need arises, contact Product Service as listed at right.

When consulting with a Service Center or Product Service, refer to the model number and serial number located on the serial label of the compressor. Proof of purchase is required for all transactions and a copy of your sales receipt may be requested.

Record the model number, serial number, and date purchased in the spaces provided below. Retain your sales receipt and this manual for future reference. Attach your sales receipt at bottom right.

Model No.

Serial No.

Date Purchased, la date d'achat, la fecha de compra



PIÈCES ET RÉPARATIONS

Pour pièces de rechange et réparations de votre Centre d'Entretien autorisé le plus proche. Au besoin, veuillez contacter le service après-vente (Product Service) au numéro de téléphone ou à droite.

Lorsque vous appelez un Centre d'Entretien ou le service après-vente, veuillez indiquer le numéro de modèle et le numéro de série situé sur la étiquette de série du compresseur. Une preuve d'achat est nécessaire lors de toute transaction et une copie de votre reçu peut être exigée.

Inscrivez la date d'achat au-dessus de, dans les espaces réservé à cet effet. Conservez votre reçu et ce manuel pour référence ultérieure. Agrafez reçu en au-dessous.

Quand vous avez besoin des services de l'usine, s'il vous plaît contactez au centre d'entretien autorisé le plus proche ou composez simplement le :

SERVICE CLIENTÉ



Au Canada
Appel gratuit
Télécopieur

1-800-445-1805
1-507-723-4772

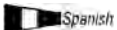

REPUESTOS Y SERVICIO

Las piezas de repuesto y el servicio están disponibles del Centro de Servicio autorizado más cercano. Consulte con el Servicio al Cliente (Product Service) listado debajo, si surge la necesidad.

Refiérase al número de modelo y el número de serie situado en la etiqueta de serie del compresor, cuando consulte con un Centro de Servicio o el Servicio al Cliente. Se requiere la prueba de compra para todas las transacciones y puede requerirse una copia de su recibo de venta.

En los espacios provisto arriba registre la fecha de compra. Guarde su recibo de venta y este manual para referencia futura. Adjunte el recibo de venta debajo.

Quando necesite servicio por favor de consultar el centro de servicio autorizado más cercano o notificar por correo a:

Product Service

118 West Rock Street
P. O. Box 206
Springfield, MN 56087 EE.UU.

24/7
1-800-445-1805
www.colemanpowermate.com
el español 308-236-4527

Attach sales receipt here.

Agrafez reçu ici.

Adjunte el recibo de venta aquí.