

# MODEL 24740A

# REPAIR PARTS GRASS BAGGER

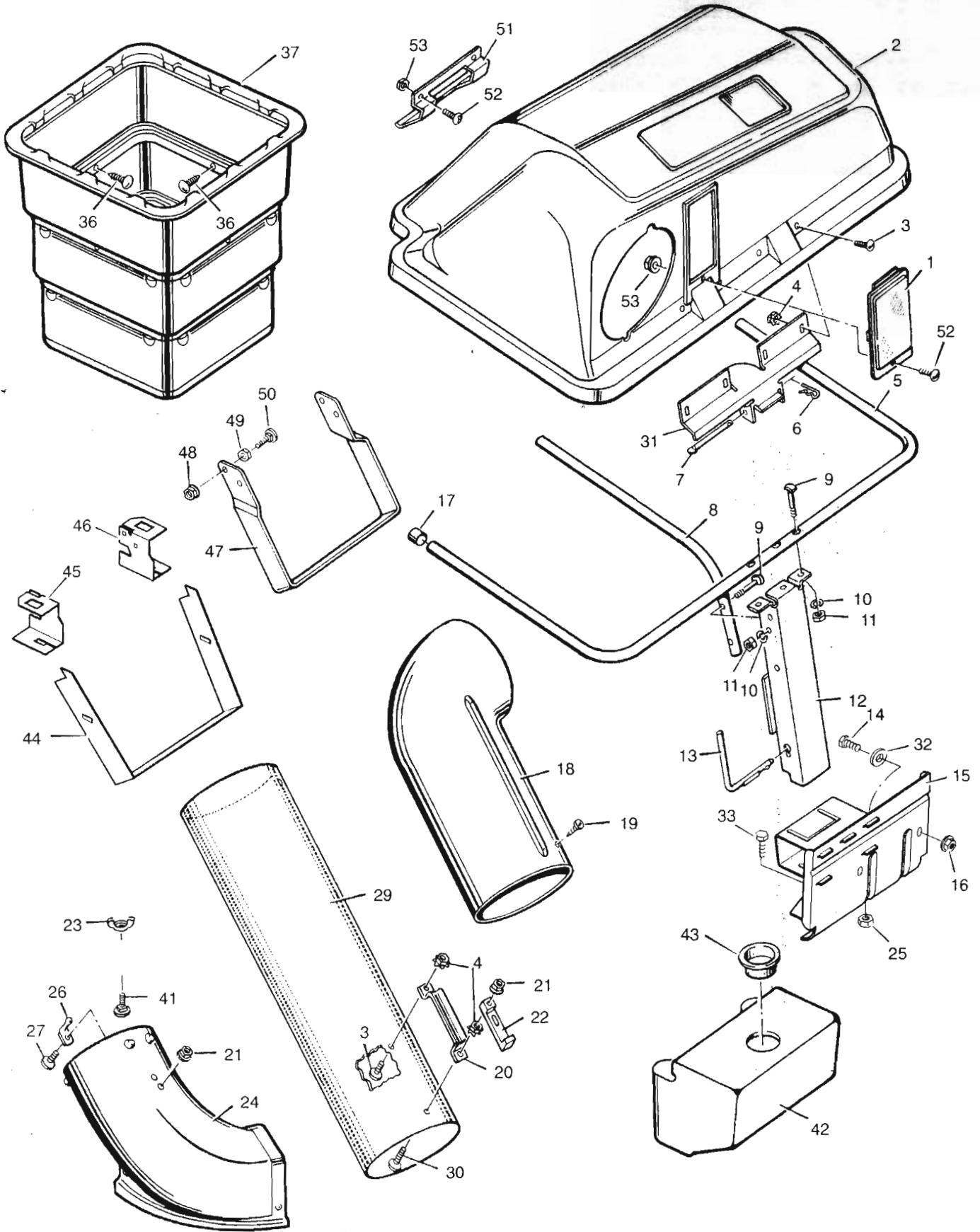

# MODEL 24740A

# REPAIR PARTS GRASS BAGGER

Key No.	Description	Part No.	Key No.	Description	Part No.
1	Window	54575	25	Hex Nut	15x41
2	Cover	54576	26	Pin, Latch	54563
3	Screw	4x24	27	Bolt, Carriage	2x39
4	Locknut	15x66	29	Tube, Connector	91967
5	Tube, "U"	54410E701	30	Screw	4x71
6	Pin, Hair	31x6	31	Hinge, Cover	54398E701
7	Pin, Hinge	54407Z	32	Washer	10851 Z
8	Tube, Center	54412E701	33	Bolt, Hex	1x125
9	Bolt, Special	6x93Z	36	Fastener, Plastic *	193x1
10	Lockwasher	18x15	37	Containers (Quantity 2)	54727SE
11	Nut, Hex	15x32	41	Bolt, Carriage	2x64
12	Channel Assembly	54422E701	42	Shell, Front Weight	55441
13	Pin, Channel	54408Z	43	Plug, Front Weight	24863
14	Bolt, Hex	1x84	44	Support, Weight (Type A)	92386E701
15	Mount Assembly, Bagger	94690E701	45	Bracket, Right Hanger	92385E701
16	Nut, Hex	15x108	46	Bracket, Left Hanger	92384E701
17	Cap, End	24862	47	Support, Weight (Type B)	54552E701
18	Elbow	91944	48	Nut, Flange	15x88
19	Screw	26x239	49	Nut, Jam	15x109
20	Handle, Connector Tube	54416E701	50	Carriage, Bolt	2x74
21	Locknut, Flange	15x89	51	Handle, Plastic	54537
22	Latch, Rubber	54695	52	Screw	4x21
23	Wingnut	14x86	53	Nut, Hex	15x81
24	Tube, Extension	54564SE	—	Book, Instruction	F-000900

# ASSEMBLY

## INTERNATIONAL SYMBOLS

**IMPORTANT:** The following symbols are located on your unit or on literature supplied with the product. Before you operate the unit, learn and understand the purpose for each symbol.



**IMPORTANT**  
Read Owner's Manual Before  
Operating This Machine.



**WARNING**  
Do Not Operate Unless Entire  
Grass Bagger Is Installed.

## ASSEMBLY

Read and follow the assembly and adjustment instructions for your

mower. All fasteners are in the parts bag. Do not discard any parts or material until the unit is assembled.



**WARNING:** Before doing any assembly or maintenance to the mower, remove the wire from the spark plug.

**NOTE:** In this instruction book, left and right describe the location of a part with the operator on the seat.

**NOTE:** Torque is measured in foot pounds (metric N.m). This measurement describes how tight a nut or bolt must be. The torque is measured with a torque wrench.

### TOOLS REQUIRED

- Pliers (1)
- Adjustable open end wrenches (2)
- Blade type screwdriver (1)
- Phillips screwdriver (1)

## GRASS BAGGER PARTS BAG – CONTENTS

The fasteners and other loose parts are shown below. The fasteners are shown at full size. The quantity is shown in brackets ( ). On some models, all of the fasteners are not required.

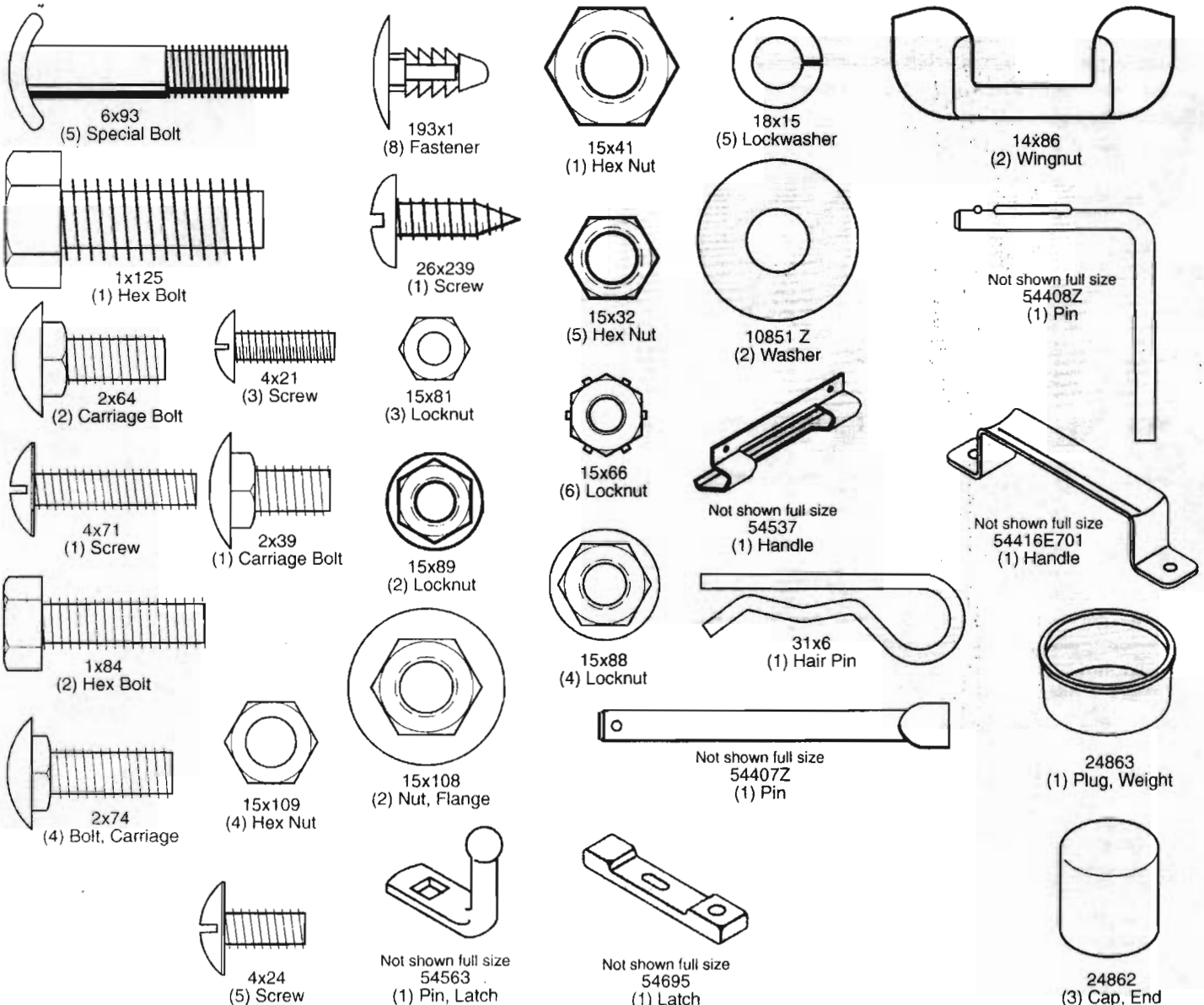

# ASSEMBLY

## HOW TO ATTACH THE BAGGER MOUNT

1. Remove and discard the two self-tapping screws from the rear of the frame. Use these two holes to attach the **bagger mount**.
2. Attach the bottom of the **bagger mount** to the frame with the fasteners (Figure 1). Do not tighten at this time.

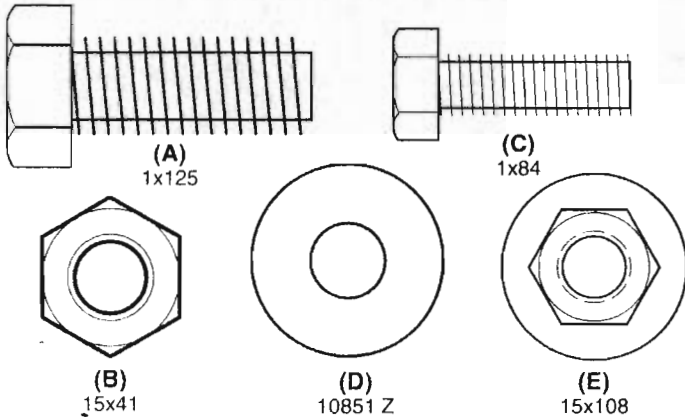

3. Attach the back of the **bagger mount** to the frame with the fasteners (Figure 1). Make sure the fasteners are tight.

**NOTE: For easier assembly, use a ratchet and socket to tighten the bolts.**

4. Tighten bolt **A** and locknut **B**.

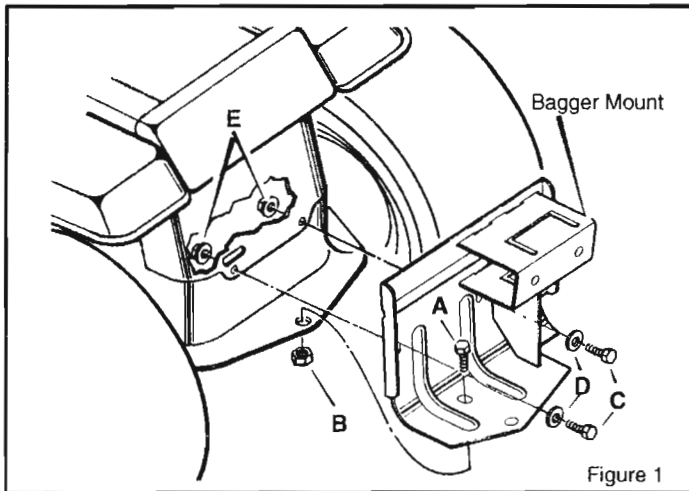

5. Mount the **channel** in the **bagger mount** (Figure 2).

**IMPORTANT: If you remove the grass bagger to mount a different pull-behind attachment, do not remove the bagger mount. Use the hitch pin hole in the bagger mount to attach a different attachment.**

6. Install the **channel pin** fully into the right side of the **channel** (Figure 3). Rotate the **channel pin** counterclockwise to lock the **channel** in place.
7. Mount the **outer tube** to the **channel** (Figure 3). Make sure the **two holes**, on the side of the **outer tube**, are on the **right side**. Use the fasteners shown full size below. Make sure the fasteners are tight.

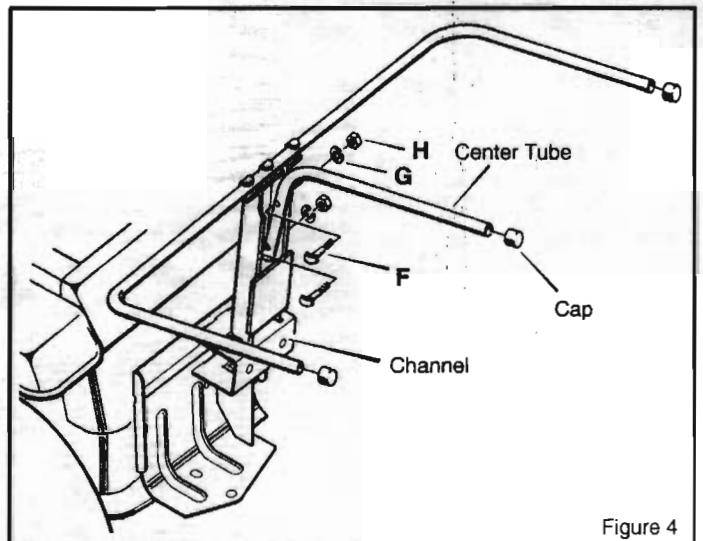
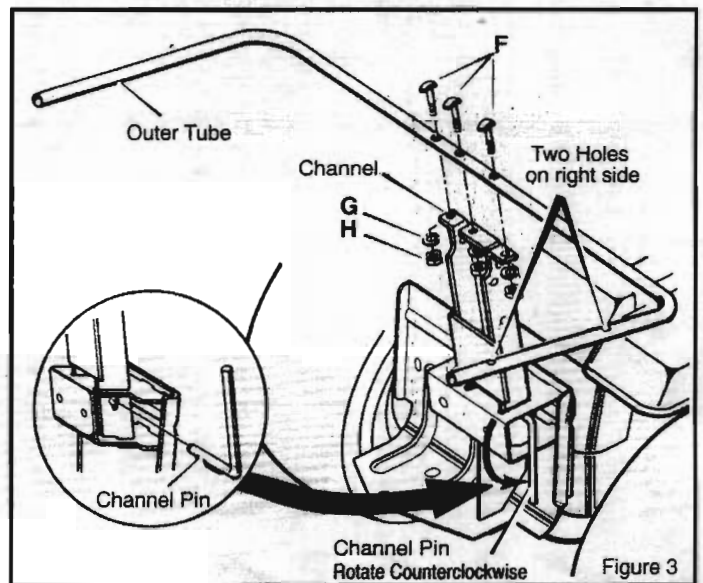
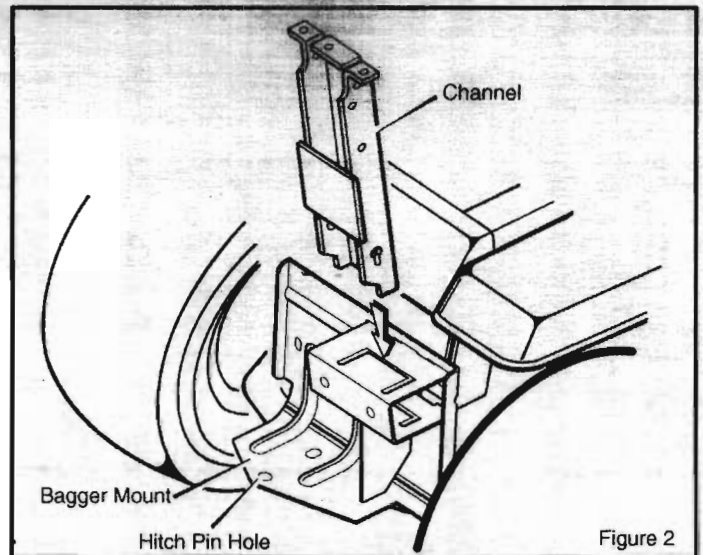
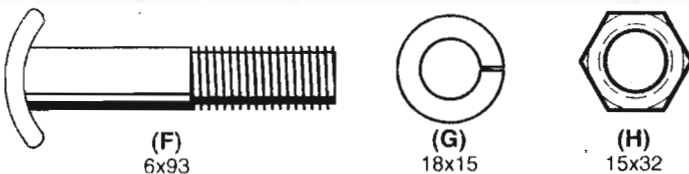

8. Mount the **center tube** to the **channel** with the fasteners (Figure 4). Make sure the fasteners are tight.
9. Attach the **caps** to the ends of the **tubes** (Figure 4).

# ASSEMBLY

## HOW TO MOUNT THE COVER

1. Assemble the **hinge** to the **cover** (Figure 5). The fasteners are shown full size below. Push the **hinge** toward the top of the **cover**. Tighten the fasteners.

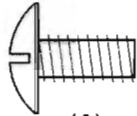

(A)  
4x24

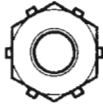

(B)  
15x66

2. Attach the **handle** to the **cover** with the fasteners (Figure 5). Tighten the fasteners.

3. Attach the **window** to the **cover** with the fasteners (Figure 6). Make sure the **tabs** are locked inside the **cover**.

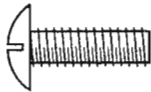

(C)  
4x21



(D)  
15x81

4. Set the **cover** in the operating position on top of the outer tube (Figure 6). Fasten the **hinge** to the **channel** with the fasteners shown below.

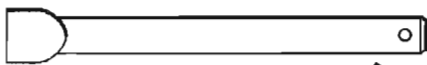

(Not Shown Full Size)

(E)  
54407Z

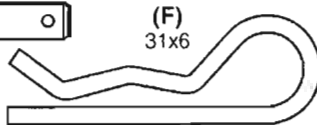

(F)  
31x6

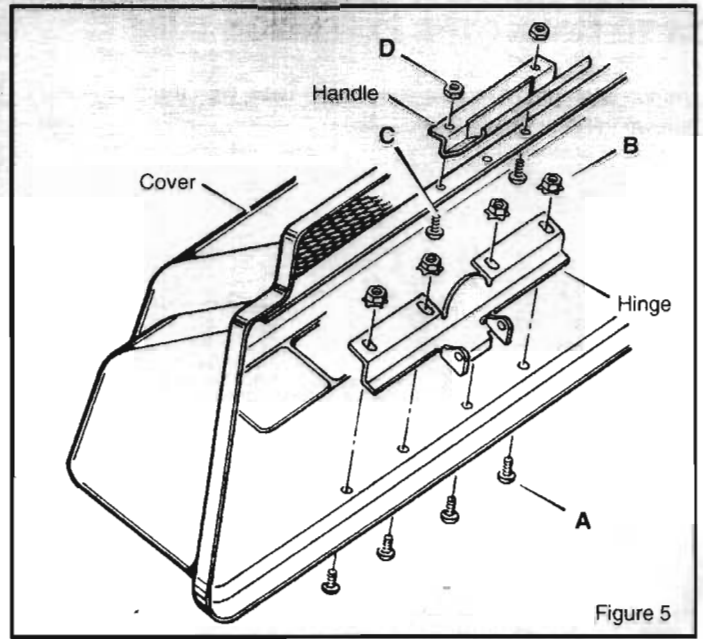

Figure 5

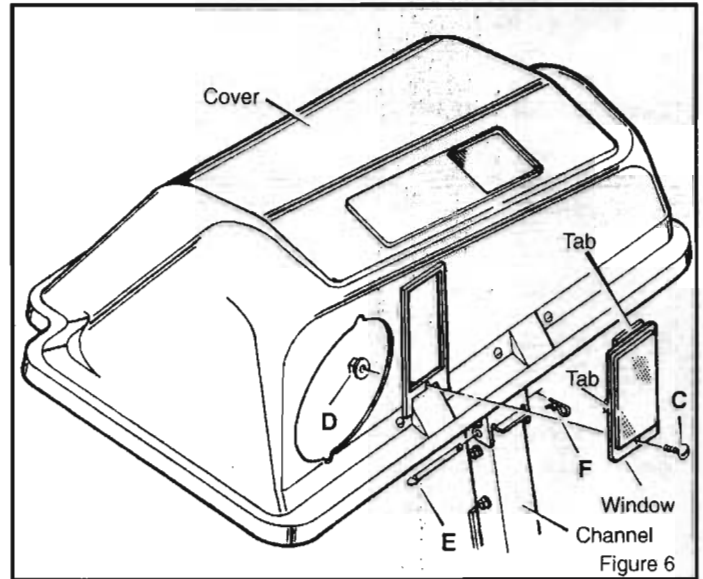
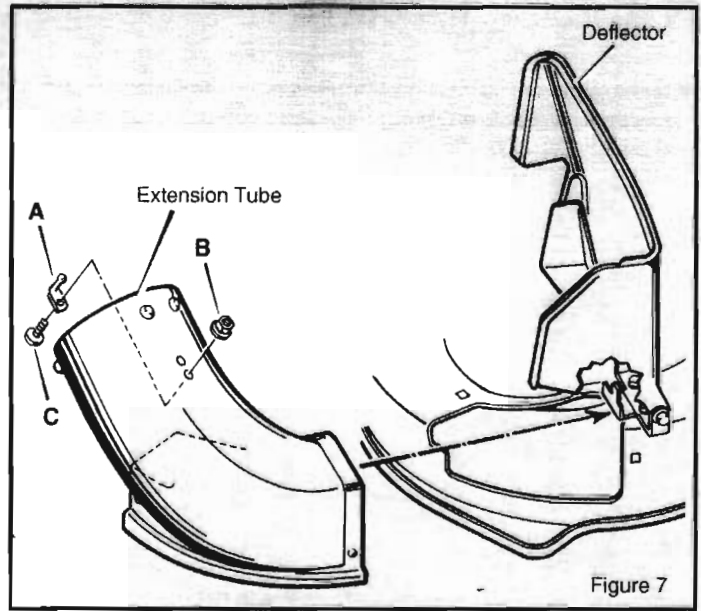
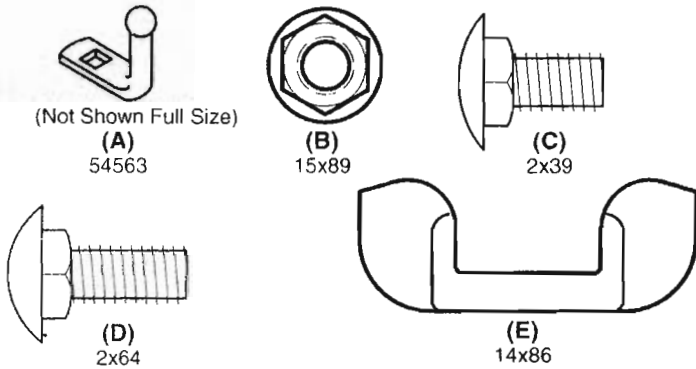

Figure 6

# ASSEMBLY

## HOW TO MOUNT THE EXTENSION TUBE

1. Attach latch pin (A) to the **extension tube** with the fasteners shown full size below (Figure 7).



2. Move the lift lever to the highest cut position.
3. Disconnect the wire from the spark plug. Raise the **deflector**. Rotate the blade away from the discharge opening.

**WARNING:** The blade has sharp edges. Always be careful of the position of the blade.

4. Slide the **extension tube** under the **deflector bracket** (Figure 8). Mount the **extension tube** to the top of the mower housing with the fasteners.
5. Attach the **extension tube** to the side of the mower housing with the fasteners. Make sure the fasteners are tight.
6. Connect the wire to the spark plug.

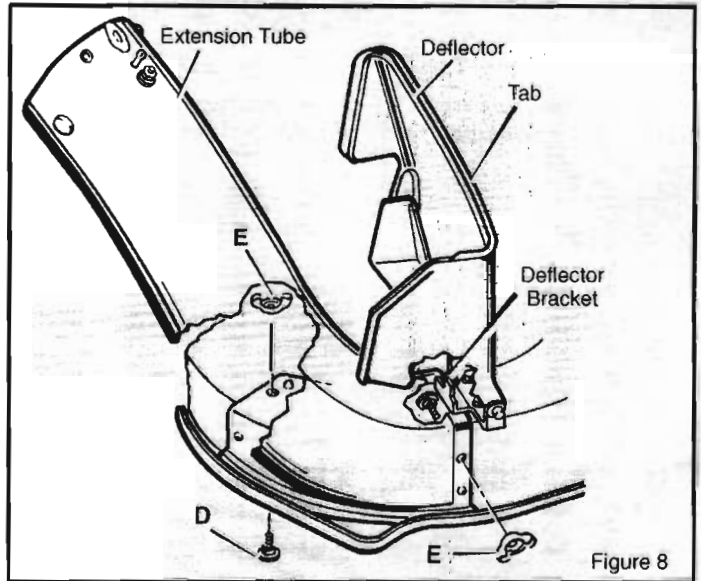

# OPERATION

## HOW TO USE THE GRASS BAGGER



**WARNING:** Do not ride up or down slopes that are too steep to back straight up. Never ride the unit across a slope. See the "Slope Guide" in the back of this book for information on how to check slopes.

### OPERATION

To operate with the grass bagger, follow the steps below.

**IMPORTANT:** Do not cut wet grass. Wet grass will not discharge correctly into the grass bagger.

1. Start the engine.
2. Move the throttle control to FAST position.
3. Move the shift lever to FIRST (1) position. To fill the containers, always operate at the slowest speed.
4. If the height of the grass is more than 3½ inches (9cm), cut the grass with the mower housing in the highest position. Then, lower the mower housing and cut the grass again. You can also cut at ½ to ⅔ of the full cutting width of the mower housing.

### CHECK AND CLEAN CONNECTOR TUBE

The **connector tube** is made of clear plastic. If the **connector tube** becomes filled with grass, clean the **connector tube** as follows.

1. Move the blade rotation control to the DISENGAGE position.
2. Move the shift lever to the neutral (N) position.
3. Engage the parking brake.
4. Stop the engine.
5. Disconnect the **rubber latch** from the **extension tube** (Figure 18).
6. Remove the **connector tube**.
7. Clean the **connector tube** and the **extension tube** with soap and water.

### HOW TO EMPTY THE CONTAINERS

Look at the **window** in the **cover** (Figure 19). When the **containers** are full, grass can be seen through the **window**. Empty the **containers** as follows.

1. Move the blade rotation control to the DISENGAGE position.
2. Move the shift lever to the neutral (N) position.
3. Engage the parking brake.
4. Stop the engine.
5. Tilt the seat forward.
6. Pull the **handle** back and raise the **cover**.
7. Remove the **containers**.

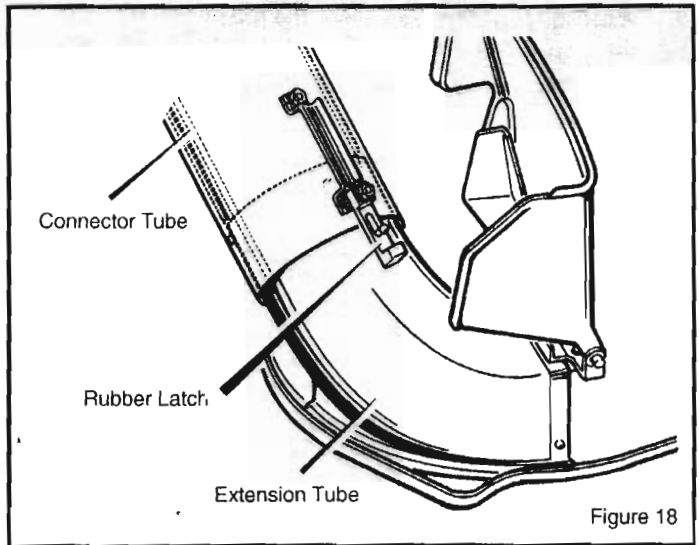

Figure 18

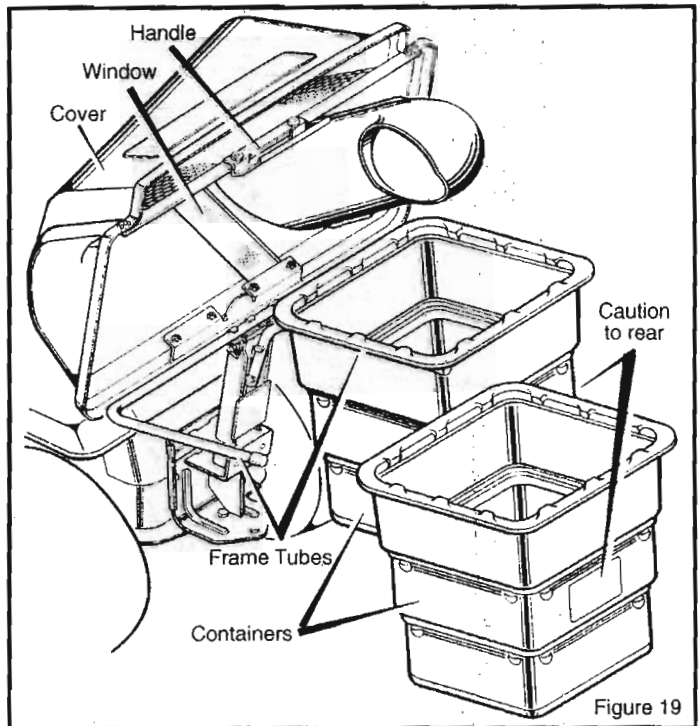

Figure 19

# MAINTENANCE

## HOW TO CLEAN THE GRASS BAGGER



**WARNING:** Before you clean the grass bagger, stop the engine and disconnect the wire to the spark plug.

For good performance, frequently clean the grass bagger as follows.

1. Disconnect the **rubber latch** from the **extension tube** (Figure 20).

2. Remove the **connector tube** from the **extension tube**.
3. Remove the **elbow** and **connector tube** from the **cover**.
4. Clean the **connector tube**, the **extension tube**, and the **elbow** with soap and water.
5. Raise the **cover**.
6. Clean the **window** with soap and water.

