

MODEL H9919946

PARTS DRAWING DESSIN DES PIÈCES ESQUEMA DE LAS PIEZAS

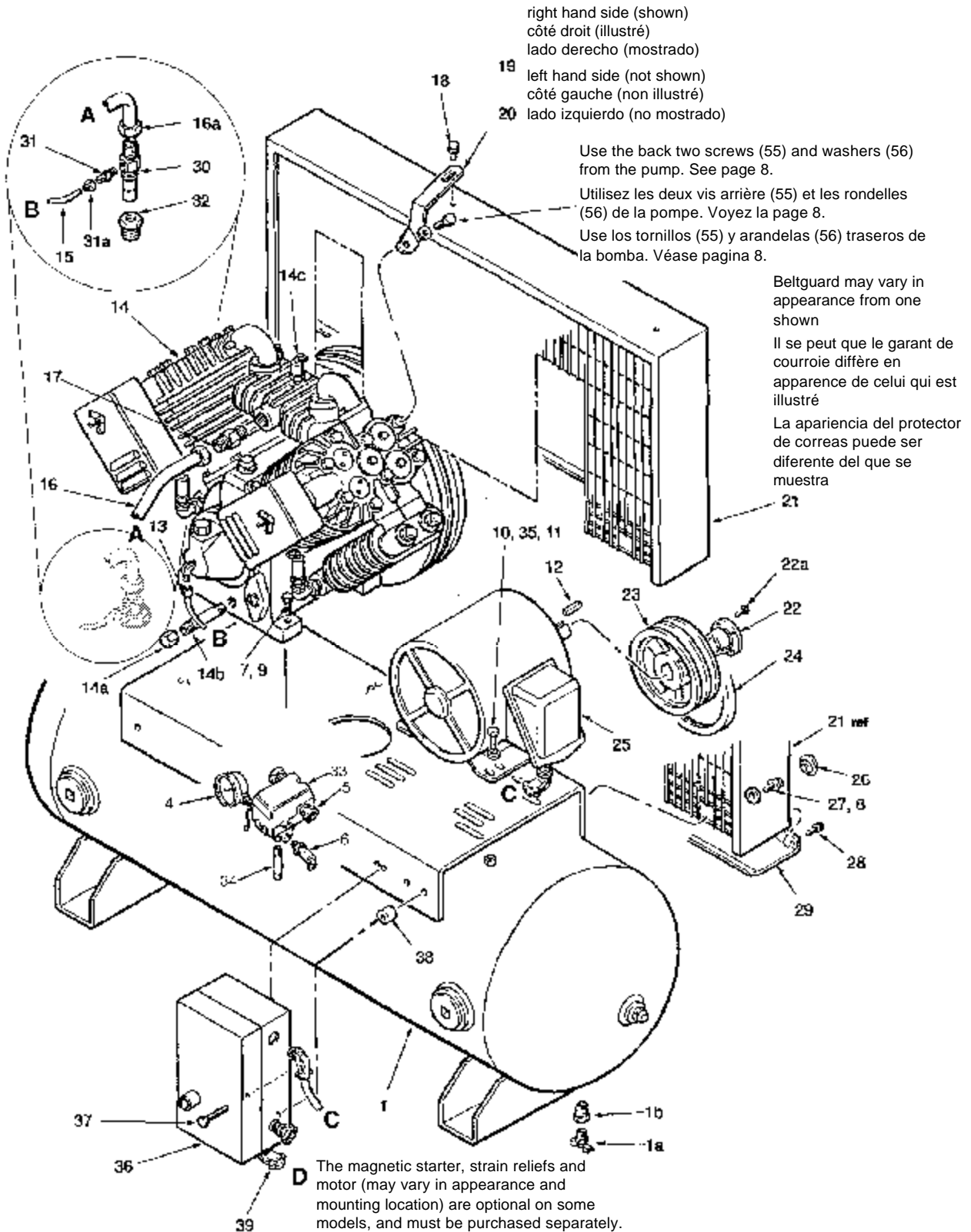

DATE 9/22/00

ORIGINAL

MODEL H9919946

PARTS DRAWING DESSIN DES PIÈCES ESQUEMA DE LAS PIEZAS

Item Art Art	Part No Nº / P Núm / P	Qty Qté Cant	Description	Description	Descripción
1	515-0353	1	Tank assy	Ensemble du réservoir	Conjunto de tanque
1a	072-0001	1	Petcock, 1/4" NPT	Robinet de décompression	Llave de desagüe
1b	063-0001	1	Bushing, 1/2" NPT x 1/4" NPT	Bague.....	Buje
2	063-0019	1	Bushing, 1" NPT x 1/4" NPT	Bague.....	Buje
4	032-0025	1	Gauge, 300 PSI.....	Jauge	Manómetro
5	071-0002	1	Strain relief connector.....	Soulagement de traction	Aliviador de esfuerzo
6	136-0007	1	Valve, relief, 200 PSI	Soupape	Válvula
7	059-0061	4	Screw, 7/16" - 14 x 2" lg.....	Vis	Tornillo
8	060-0023	4	Washer, 3/8"	Rondelle.....	Arandela
9	058-0011	4	Nut, 7/16" - 14	Écrou.....	Tuerca
10	059-1007	4	Screw, 3/8" - 16 x 1" lg.....	Vis	Tornillo
11	058-0009	4	Nut, 3/8" - 16, heavy	Écrou.....	Tuerca
12	146-0007	1	Key 5/16" x 3/16" x 1 1/4" lg.....	Clé.....	Chaveta
13	058-0017	1	Compression nut & sleeve.....	Écrou de compression	Tuerca de compresión
14	040-0212	1	Pump assy	Pompe.....	Bomba
14a	062-0101	1	Cap, pipe, 3/8" NPT	Capuchon.....	Tapa
14b	065-0040	1	Nipple, 3/8" NPT x 4" lg	Manchon fileté.....	Niple
14c	136-0047	1	Valve, relief, 225 PSI	Soupape	Válvula
14d	136-0046	2	Valve, relief, 75 PSI	Soupape	Válvula
15	145-0212	1	Tube, bleeder, B to B (copper)	Tube.....	Tubo
16	145-0239	1	Tube, transfer, A to A (copper).....	Tube.....	Tubo
			include item 16a		
16a	N/A	2	Nut, flared	Écrou.....	Tuerca
17	068-0504	1	Connector	Connecteur.....	Conector
18	059-0012	2	Bolt, lock 5/16" - 18 x 1/2" lg.....	Boulon	Perno
19	114-0188	1	Bracket, belt guard, 45° bend.....	Support.....	Soporte
			right hand (shown)		
20	114-0189	1	Bracket, belt guard, 45° bend.....	Support.....	Soporte
			left hand (not shown)		
21	142-0085	1	Beltguard	Garant de courroie.....	Protección de correa
22	004-0002	1	Hub	Moyeu	Cubo
22a	N/A	2	Screw, 1/4" x 3/4" lg.....	Vis	Tornillo
23	006-0031	1	Pulley	Poulie	Polea
24	008-0059	2	V-belt, B80	Courroie	Correa
25	160-0247	1	Motor, 10 HP 230/460V	Moteur	Motor
	160-0042	or	Motor, 10 HP 208V	Moteur	Motor
26	093-0005	5	Plug, button.....	Bouchon	Tapón
27	059-0164	4	Screw, 3/8" - 16 x 3/4" lg.....	Vis	Tornillo
28	061-0005	4	Screw, #10 x 3/4" lg.....	Vis	Tornillo
29	125-0120	1	Underpan	Tôle inférieure.....	Bandeja inferior
30	031-0059	1	Check valve, flared	Clapet de retenue.....	Válvula de contraflujo
31	068-0002	1	Connector	Connecteur.....	Conector
31a	058-0017	1	Compression nut & sleeve.....	Écrou de compression	Tuerca de compresión
32	063-0011	1	Bushing.....	Bague.....	Buje
33	034-0120	1	Switch, pressure	Interrupteur.....	Interruptor
34	065-0005	2	Nipple, 1/4" NPT x 2 1/2" lg	Manchon fileté.....	Niple
35	060-0005	4	Washer	Rondelle.....	Arandela
must be purchased separately			doit etre archete separement se debe comprar por separado		
36	001-0156	or	Magnetic starter, 230V.....	Demarreur magnetique.....	Arrancador magnetico
	001-0142	1	Magnetic starter, 460V		
	001-0151	1	Magnetic starter, 200/208V		
37	059-0245	2	Screw.....	Vis.....	Tornillo
38	114-0220	2	Spacer.....	Entretoise.....	Espaciador
39	N/A	1	Strain relief, 3/8" straight.....	Soulagement de traction.....	Aliviador de esfuerzo
	N/A	1	Strain relief, 3/8" 90°		
	N/A	1	Strain relief, 1/2" 90°		

*N/A - These are standard parts available at your local hardware store.

*N/A - Ces pièces sont des pièces standard disponibles en quincaillerie.

*N/A - Estas son piezas estándares disponibles en su ferreteria local.

DATE 9/22/00

ORIGINAL